

## COMMANDER 18-6

### Automatic Single Tank Door Type Dishwasher

- Automatic door type, single tank dishwasher with timed wash and rinse cycle
- 0.72 gallon/rack
- Capacity is 65- 20" x 20" racks per hour or 1625 dishes per hour
- Fully automatic operation
- RackAware™ Automatic Rack Sensing System\* only runs a cycle when a rack is present
- Selectable 2 minute extended wash cycle
- Field convertible straight through to corner
- Single digital temperature indicator for wash and rinse temperature



RackAware™ Automatic Rack Sensing System\* only runs a cycle when a rack is present

### STANDARD FEATURES

- SureFire® Start-Up & Check-Out Service
- Non-proprietary commercially available pump motor and parts
- "Easy Clean" front-mounted wash tank
- Single scrap screen design
- Tank heat: 5 Kw electric immersion heater or steam tank coils
- Top-mounted NEMA 12 control panel
- Single point electrical connection: motor, controls, heater and optional built-in booster (when selected)
- Door safety switch
- Low water protection
- Override switch for de-liming or extended wash cycle on front control panel
- Vent fan connection provision
- Easy-glide doors
- Detergent connection provision
- Manifold clean-out brush
- S/S frame, legs and feet
- S/S front panel
- End caps/pipe plugs secured to prevent loss

### OPTIONS

- Pressure reduction valve and line strainer
- Stainless steel steam coil tank heat
- Steam booster
- Built-in electric booster
- Remote electric booster
- Security package
- Totally enclosed motor
- Door activated drain closer
- Plastic 20" x 20" racks (plate or silver)
- Drain quench system



\* Patent Pending

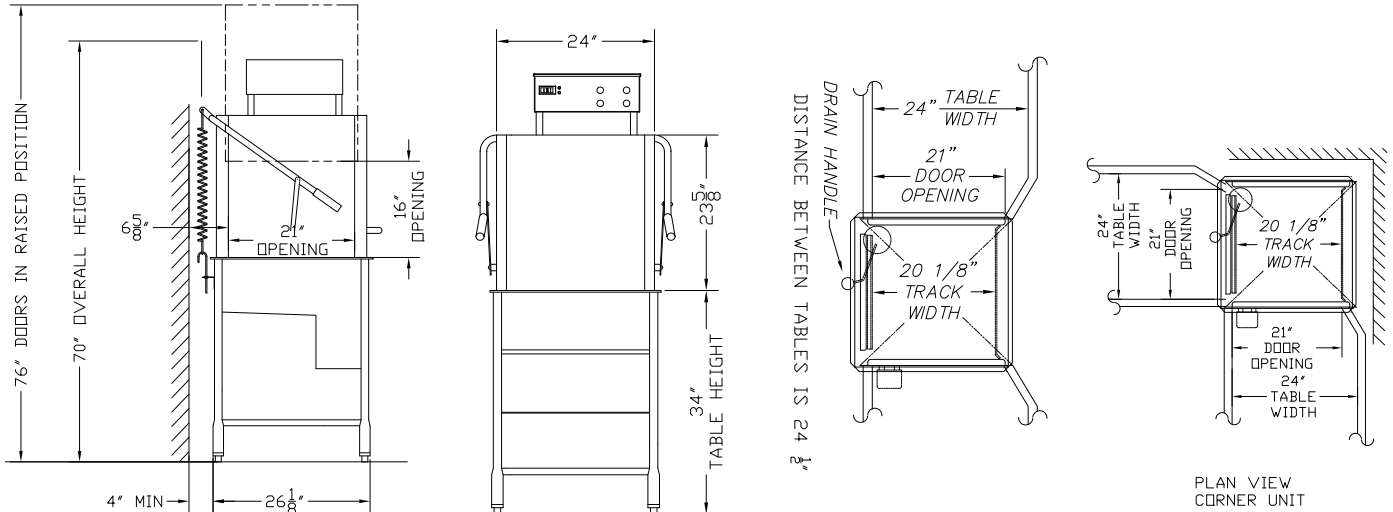

**Note:** For all rough in connections see installation and layout detail drawing.

Capacity Per Hour	65 racks 1625 dishes 80-160 meals		
Tank Capacity	6.4 gallons		
Motor Size	1 hp (wash)		
Electric Usage	3.8 Kw 208v 5.0 Kw 240v 3.1 Kw 380v 5.0 Kw 480v  Built-in booster 40° or 70° rise 10.1 Kw 208v 13.5 Kw 240v 13.5 Kw 380v 13.5 Kw 480v  6.0 Kw remote booster 40° rise 12.0 Kw remote booster 70° rise		
Steam Consumption at 20 psi min.	11 lbs./hour tank 22 lbs./hour booster 40° rise 43 lbs./hour booster 70° rise		
Final Rinse Peak Flow at 20 psi min.	4.36 gallons/minute		
Final Rinse Consumption at 20 psi min.	47 gallons/hour 0.72 gallons/rack		
Exhaust Hood Requirement	500 cfm		
Peak Rate Drain Flow	9 gallons/minute		
Shipping Weight	400 lbs.		
Current Draw Amps	Steam	Electric w/o booster	Electric w/ built-in booster
208/1/60	9.3	27.6	76.4
240/1/60	8.1	28.9	85.2
208/3/60	5.1	15.6	43.7
240/3/60	4.2	16.2	48.7
380/3/50	2.8	7.5	28.1
480/3/60	2.3	8.3	24.5

Note: Due to product improvement we reserve the right to change information and specifications without notice.

## SPECIFICATIONS

**CONSTRUCTION-** Hood and tank constructed of 16 gauge type 304 S/S. Hood unit of all welded seamless construction. S/S frame, legs and feet. All internal castings are non-corrosive lead free nickel alloy or bronze.

**DOORS-** Three (both sides and front) simultaneously opening doors. Operating doors have fingertip control, balanced by externally mounted springs. (Corner installations have two simultaneously opening doors at right angles.) All doors have easy-glide strips. Extra large die formed type 304 S/S doors ride in all S/S channels. A triple ply leading edge on the door channels made of S/S.

**PUMP-** Centrifugal type "packless" pump with a brass petcock drain. Construction includes ceramic seal and a balanced cast impeller on a precision ground stainless steel shaft, extension or sleeve. All working parts mounted as an assembly and removable as a unit without disturbing pump housing. One 1 hp motor, standard horizontal C-face frame, drip proof, internally cooled with ball-bearing construction.

**CONTROLS-** Top mounted control cabinet, NEMA 12 rated, housing motor controls and overload protection, transformer, contactors and all dishwasher integral controls. Integrated rack sensing system.

**SPRAY SYSTEM-** Wash and rinse spray systems made of type 304 stainless steel pipe threaded into cast hub assemblies. Upper and lower wash and rinse spray assemblies are removable without the use of tools.

**WASH-** 2 power spinning wash arms above and 2 power spinning wash arms below. On top, each wash arm is designed with 8 nozzles (16 total). On the bottom, each wash arm is designed with 4 slots (8 total). The slots are precision milled for water control and produce a fan spray.

**FINAL RINSE-** 2 power spinning rinse arms above and 2 power spinning wash arms below. On top, each rinse arm is designed with 2 nozzles (4 total). On the bottom, each rinse arm is designed with 4 nozzles (8 total). The nozzles produce a fan spray reducing water consumption, maximizing heat retention.

**DRAIN-** Drain valve externally controlled. Overflow assembly with skimmer cap is removable without the use of tools for drain line inspection. Heater is protected by low water level control.