

ENSIGN 40-2

Single Tank Counter Type Dishwasher

- Automatic counter type single tank dishwasher with pass-thru telescoping hood
- 0.75 gallons/rack
- Capacity is 43- 16" x 16" racks per hour or 720 dishes
- No venting required
- A timed wash and rinse cycle
- Fully automatic operation with power on/off button
- Cycle starts when door is closed



STANDARD FEATURES

- Tank heat: electric immersion heater
- Thermometer for wash
- Thermometer for final rinse
- Vacuum breaker
- Manifold clean-out brush
- Automatic tank fill
- Low water protection
- Detergent connection provision
- Space saving compact design
- Single point electrical connection: motor, controls, tank heat. (Optional booster requires separate connection)
- Fully automatic operation
- Side mounted control panel (NEMA 12)
- Simplified scrap screen design
- Standard frame drip proof motor
- Door safety switch
- SureFire® Start-Up and Check-Out Service

OPTIONS

- Stainless steel steam coil tank heat
- Pressure reduction valve and line strainer
- S/S frame
- Steam booster
- Remote electric booster
- Totally enclosed motor
- Plastic 16" x 16" racks (2 plate racks or 2 silver racks)

Ensign 40-2

AUTOQUOTES



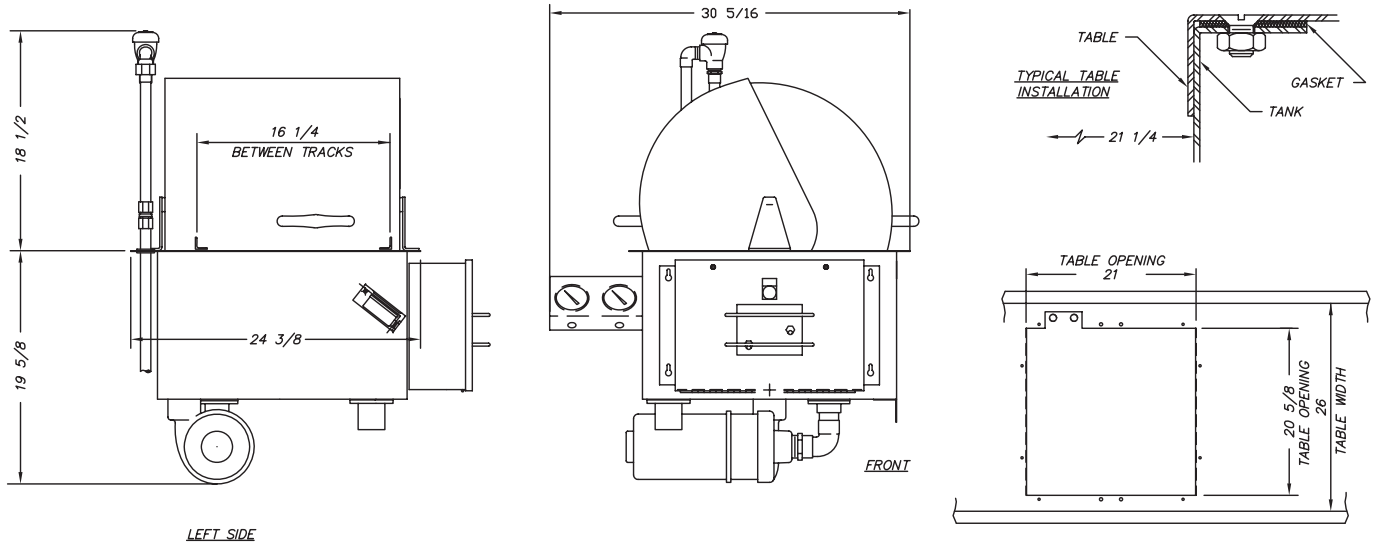

Note: For all rough in connections see installation and layout detail drawing.

Capacity Per Hour	43 racks 720 dishes	
Tank Capacity	8.1 gallons	
Motor Size	1/2 hp (wash)	
Electric Usage	1.5 kW wash tank 6 kW booster 40° rise 12 kW booster 70° rise	
Steam Consumption at 20 psi min.	6 lbs./hour tank 22 lbs./hour remote booster 40° rise 38 lbs./hour remote booster 70° rise	
Final Rinse Peak Flow at 20 psi min.	4.1 gallons/minute	
Final Rinse Consumption at 20 psi min.	34 gallons/hour 0.75 gallons/rack	
Exhaust Hood Requirement	N/A	
Peak Rate Drain Flow	9 gallons/minute	
Shipping Weight	400 lbs.	
Current Draw Amps	Steam	Electric w/o booster
115/1/60	10.7	24.0
240/1/60	5.5	11.8
208/3/60	2.7	6.9
240/3/60	2.4	6.0
380/3/50	1.5	3.8
480/3/60	1.4	3.1

SPECIFICATIONS

CONSTRUCTION- Hood and tank constructed of 16 gauge type 304 S/S. Hood unit of all welded seamless construction. All internal castings are non-corrosive lead free nickel alloy or bronze.

DOORS- Two opening operating doors. Operating doors have fingertip control, rotating on S/S bracket. Doors formed of 18 gauge S/S.

PUMP- Centrifugal type "packless" pump with a brass petcock drain. Construction includes ceramic seal and a balanced cast impeller on a precision ground stainless steel shaft, extension or sleeve. All working parts mounted as an assembly and removable as a unit without disturbing pump housing. One 1/2 hp motor, standard horizontal C-face frame, drip proof, internally cooled with ball-bearing construction.

CONTROLS- Side-mounted control cabinet, housing motor controls and overload protection, transformer, contactors and all dishwasher integral controls. All controls safe low voltage 24 VAC.

SPRAY SYSTEM- Wash and rinse spray systems made of 18-8 type 304 S/S pipe.

WASH- Power wash arm above with 14 high pressure action cleaning slots and 6 power wash arms below, each designed with 5 high pressure action cleansing slots. The slots are precision milled for water control producing a fan spray. Wash arms are removable without the use of tools.

FINAL RINSE- 1 spray body above designed with 4 power rinse nozzles and 1 power rinse coil below designed with 6 nozzles.

DRAIN- Overflow assembly with skimmer is removable without use of tools for drain line inspection. Heater protected by low water level controls.

Note: Due to product improvement we reserve the right to change information and specifications without notice.