

SW-12-P

Performer Series Pass-Thru Pot and Pan Washer

- Automatic door type utensil washer with timed wash and rinse cycle
- 13 racks per hour. 12 pans per rack
- Timers are all adjustable
- Fully automatic operation with power on/off button
- Cycle starts when doors are closed
- Hold down rack system for secure washing
- Available in front load, corner and pass-thru operations



STANDARD FEATURES

- Wash tank heat: electric, gas, steam injection or steam coil
- Pressure regulator
- Single point electrical connection
- Low water cut-off
- Automatic fill
- Three position wash selector (complete cycle times): Light (260 seconds), Medium (380 seconds), Heavy (500 seconds)
- Emergency cycle stop button
- Wash pump pressure gauge
- Rinse pressure gauge
- Digital temperature controller for wash and rinse
- Pan washer clean-up hose and spray gun
- Lift-up door design
- Detergent connection provisions
- SureFire® Start-Up & Check-Out Service

OPTIONS

- Stainless steel steam coil tank heat
- Pressure reduction valve and line strainer
- Steam booster
- Electric booster
- Security package
- Totally enclosed motor
- Recommended option: power vent fan



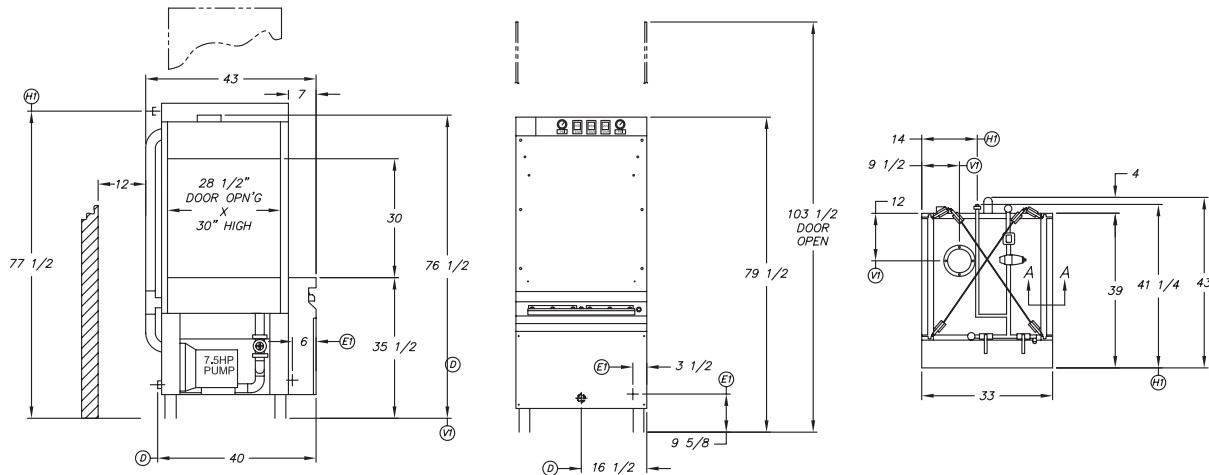

Note: For all rough in connections see installation and layout detail drawing.

SPECIFICATIONS

Capacity Per Hour	13 racks/156 sheet pans			
Tank Capacity	30 gallons			
Motor Size	7 1/2 hp (wash)			
Electric Usage	Electric wash heat (1) 9kW element Rinse booster (1) 9 Kw element			
Steam Consumption at 10-15 psi	18 lbs./hr. injected (wash tank) 36 lbs./hr. coil (wash tank)			
Gas Consumption	36,000 BTUH 35 CFH natural gas 7" W.C. minute 14 CFH propane 11" W.C. minute			
Final Rinse Peak Flow at 20 psi min.	4.5 gallons/minute			
Final Rinse Consumption at 20 psi min.	49.5 gallons/hour 4.5 gallons/cycle			
Exhaust Hood Requirement	6" steam exhaust vent			
Peak Rate Drain Flow	5 gallons/minute			
Shipping Weight	1050 lbs.			
Current Draw Amps	Electric	Gas	Steam Injector	Steam Coil
208/3/60	71.0	46.0	46.0	21.0
230/3/60	65.2	42.6	42.6	20.0
460/3/60	33.6	22.3	22.3	11.0

CONSTRUCTION- Hood and tank constructed of 14 gauge series 300 S/S. Hood unit of all welded seamless construction. 12 gauge series 300 S/S frame, S/S legs and feet. All internal castings are non-corrosive bronze.

DOORS- Two simultaneously opening doors in-line with each other. Operating door has fingertip control, balanced by an externally mounted counterweight. (Corner installations have two simultaneously opening doors at right angles.) Extra large die formed series 300 S/S doors ride in all S/S channels with easy-glide liners.

PUMP- Centrifugal type "packless" pump with a drain plug. Construction includes ceramic seal and a balanced cast impeller on a precision ground stainless steel shaft, extension or sleeve. All working parts mounted as an assembly and removable as a unit without disturbing the unit piping. One 7-1/2hp motor, standard horizontal C-face frame, drip proof, internally cooled with ball-bearing construction.

CONTROLS- Electro-mechanical controls, including motor controls and overload protection, transformer, contactors and all dishwasher integral controls.

SPRAY SYSTEM- Wash and rinse spray systems made of type 304 stainless steel tubing. The wash assembly arm is pinned into hub assembly. Upper and lower wash assemblies are removable without the use of tools. Rinse spray assemblies are removable with the use of simple tools.

WASH- 1 full width power spinning wash arm above and 1 full width power spinning wash arm below.

FINAL RINSE- Top and Bottom stationary final rinse nozzles. The nozzles produce a cone spray reducing water consumption, maximizing heat retention.

DRAIN- Drain valve externally controlled. Overflow assembly with skimmercap is removable with the use of simple tools for drain line inspection. Heater is protected by low water level control.

EXHAUST- A 6-inch diameter exhaust vent companion flange is supplied on the top of the unit.

Note: Due to product improvement we reserve the right to change information and specifications without notice.