

TD 321-3

AUTOMATIC TRAY DRYER OPTIONAL COMPONENT

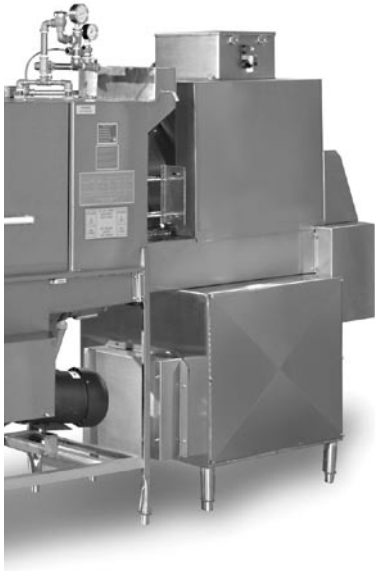

DESIGN

Automatic conveyor, tray dryer with Insinger's unique Air Wiper design. Capacity is compatible with the traywasher and based on a 15" tray. Designed for left or right hand conveyor travel, as specified. Furnished only as an added component to a TRAC 321-2, TRAC 321-2 RPW or TRAC 878 traywasher.

STANDARD EQUIPMENT

- S/S frame, legs and feet
- Top mounted NEMA 12 control panel
- SureFire™ Start-Up and Check-Out Service

OPTIONAL ACCESSORY EQUIPMENT

- Security package

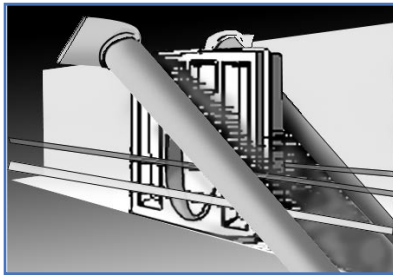

The TD 321-3 completes Insinger's powerful tray drying system using the unique Air Wiper (shown at left) which leaves the trays virtually free of water.



6245 State Road
Philadelphia, PA 19135-2996
215-624-4800
215-624-6966 FAX
800-344-4802
www.insingermachine.com

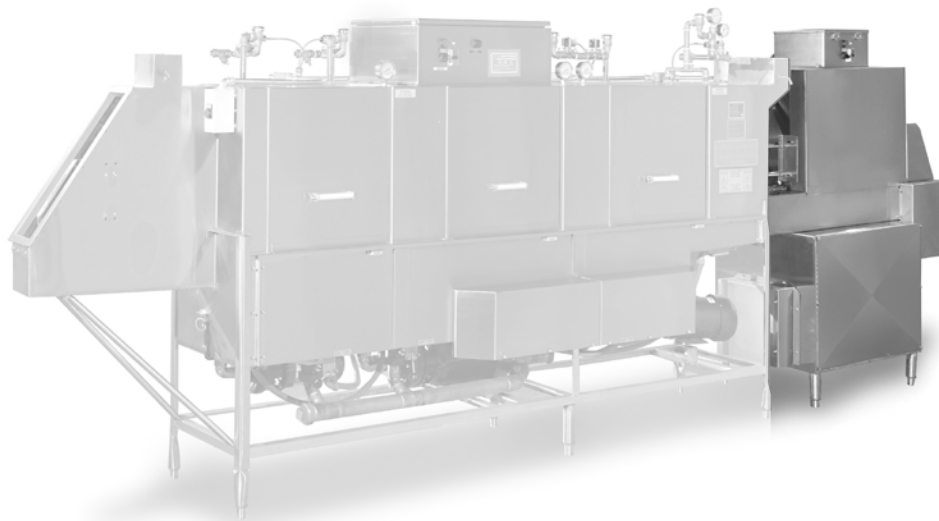

CSI - 11400

SPECIFICATIONS

CONSTRUCTION - Hood and tank constructed of 16 gauge 18-8 type 304 S/S. Hood unit of all welded seamless construction. S/S frame, legs and feet.

CONVEYOR - One S/S roller conveyor chain with tray cradles, through both washer and dryer. Width between guide rails is factory adjustable from 1.5" to 3.7". Conveyor accommodates trays up to 15" high. Conveyor drive system includes direct drive gear motor with frictionless, trouble-free overload release system continuously running.

CONTROLS - Top-mounted control cabinet, NEMA 12 rated, housing motor controls and overload protection, transformer and contactor. All controls safe low voltage 24 VAC.

BLOWER - 10 HP regenerative blower with Insinger's specially designed "air wiper" mounted on either side of conveyor. "Air wipers" are mounted on a diagonal to sweep water in controlled movement preventing splashing and uneven results.

DRAIN - All water is drained back into TRAC 321-2 or TRAC 321-2 RPW with a gravity drain connection. Factory installed drain connection to tray washer provided if dryer is ordered with a TRAC 321-2 or TRAC 321-2 RPW.

UNLOAD TABLE - A stainless steel tray unload table receives clean trays. Table constructed with guide rails which ease the trays onto table.

Capacity per hour	Motor size	Shipping weight	Additional current draw amps when connected to traywasher	Electric Customer Fuse
528 trays	10 hp (blower) 1/15 hp (conveyor)	700 lbs.	208/3/60	31.0FRN-R-60
			240/3/60	28.2FRN-R-60
			380/3/50	17.0FRS-R-35
			480/3/60	14.1FRS-R-30